

Lab 13

Ammeter, Voltmeter, and Ohmmeter

A. Purpose

To understand the structure of an ammeter, voltmeter, and ohmmeter, and to measure the current, voltage, and resistance of the circuit by self-made meters.

B. Introduction

A meter is a device built to accurately detect and display an electrical quantity in a readable form. The display mechanism of a meter is often referred to as a movement, borrowing from its mechanical nature to move a pointer along a scale so that a measured value may be read. Modern digital meters, however, have no moving parts; the term “movement” may be applied to the same basic device performing the display function. The design of digital “movements” is beyond the scope of this experiment, but mechanical meter movement designs are very understandable. Most mechanical movements are based on the principle of electromagnetism that the electric current through a conductor produces a magnetic field perpendicular to the axis of electron flow.

The first meter movements built were known as galvanometers and were usually designed with maximum sensitivity in mind. A very simple galvanometer may be made from a magnetized needle suspended from a string and positioned within a coil of wire. Current through the wire coil will produce a magnetic field that will deflect the needle from pointing in the direction of the earth’s magnetic field. An antique string galvanometer is shown in Fig. 1.

Practical electromagnetic meter movements can be made with a pivoting wire coil suspended in a strong magnetic field, shielded from the majority of outside influences. Such an instrument design is generally known as permanent-magnet, moving coil PMMC movement, as Fig. 2 shows. An increase in measured current will drive the needle to point further to the right and a decrease will cause the needle to drop back down toward its resting point on the left. The arc on the meter display is labeled with numbers to indicate the value of the quantity being measured. That is, if it takes $50 \mu\text{A}$ of current to drive the needle fully to the right, the scale would have $0 \mu\text{A}$ at the very left end and $50 \mu\text{A}$ at the very right, $25 \mu\text{A}$ being marked in the middle of the scale. In all likelihood, the scale would be divided into much smaller graduating marks, every $5 \mu\text{A}$ or $1 \mu\text{A}$, for example, to allow a more precise reading from the needle’s position.

The meter movement has a pair of metal connection terminals for the current to enter and exit. Most meter movements are polarity-sensitive, with one direction of current driving the needle to the right and the other driving it to the left. Common polarity-sensitive movements include the D’Arsonval and Weston designs, both PMMC-type instruments. Current in one direction through the wire will produce a clockwise torque on the needle mechanism, while

current in the other direction will produce a counter-clockwise torque. In electromagnetic movements, there will be a “full-scale current” (I_F) necessary to rotate the needle so that it points to the exact end of the indicating scale. The task of the meter design is to take a given meter movement and design the necessary external circuitry for full-scale indication at some specified amount of voltage or current. By making the sensitive meter movement part of a voltage or current divider circuit, the movement’s useful measurement range may be extended to measure far greater levels than what could be indicated by the movement alone. ***Precise resistors are used to create the divider circuits necessary to divide voltage or current appropriately.*** In this lab, you are going to use D’Arsonval meter and resistors to design the divider circuits, the ammeter, voltmeter, and ohmmeter, and to test their accuracy.



Fig. 1. An antique string galvanometer

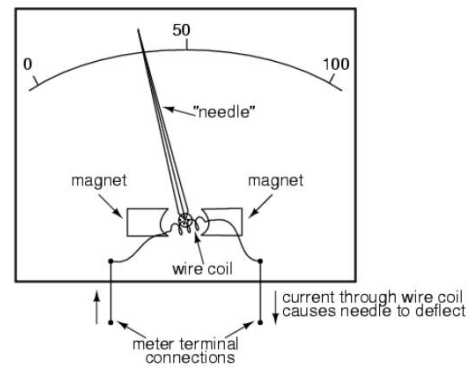

Fig. 2. permanent-magnet, moving coil, or PMMC movement

C. Apparatus



D. Procedures

1. Pre-lab assignments (hand in before the experiment)
 - (1) See the following link for the instructions of multimeter:

<https://learn.sparkfun.com/tutorials/how-to-use-a-multimeter/all>

- (2) Make a flowchart of this experiment and answer the questions.
- (3) In the following questions, you are going to design an ammeter, voltmeter, and ohmmeter respectively by a galvanometer and an external resistor of resistance R_e . Suppose that the given galvanometer has full-scale current I_F and internal resistance R_G , and the currents flow through the galvanometer and the external resistor are labeled by I_G and I_e , respectively.
- (i) A meter designed to measure electrical current is called an “ammeter.” In ammeter designs, an external resistor added to extend the usable range of the galvanometer is connected *in parallel* with the galvanometer so as to divide the measured current going to the galvanometer.
- (a) Draw a schematic of an ammeter.
- (b) Find the total current that flows through the “ammeter” in terms of I_G , R_G , R_e .
- (c) If $I_F = 50 \mu\text{A}$ and $R_G = 1.2 \text{ k}\Omega$, find the resistance R_e of the parallel resistor such that the maximum current measured by the ammeter is 5 mA .
- (d) Following (c), if the current I_G read from the galvanometer is now $20 \mu\text{A}$, find the current flows through the self-made ammeter.
- (ii) A meter designed to measure the voltage across it is called a “voltmeter.” In voltmeter design, an external resistor added to extend the usable range of the galvanometer is connected *in series* with the galvanometer so as to divide the voltage across the galvanometer’s connection points.
- (a) Draw a schematic of a voltmeter.
- (b) Find the resistance R_e of the serial resistor in terms of I_F , R_G , V_{ab} such that the full-scale galvanometer equivalently represents the voltage difference V_{ab} across the voltmeter.
- (c) If $I_F = 50 \mu\text{A}$ and $R_G = 1.2 \text{ k}\Omega$, find the resistance R_e of the serial resistor added to the galvanometer such that the maximum voltage measured by the voltmeter is 10 V .
- (d) Following (c), if the current I_G read from the galvanometer is now $15 \mu\text{A}$, what is the voltage measured by this self-made voltmeter?
- (iii) A meter used to measure the resistance of the specific resistor is called an “ohmmeter.” In ohmmeter design, under the given voltage ε , an external resistor is connected *in series* with the galvanometer to divide the voltage across the meter galvanometer’s connection points.
- (a) Find the resistance R_e of the serial resistor in terms of I_F , R_G , ε such that the full-scale deflection occurs.
- (b) Following (a), if an unknown resistor is now connected to the circuit, you would see the indicated current from the galvanometer to be smaller than

I_F , and then the difference of the readings can be used to obtain the resistance R of this resistor. Prove that

$$R = \frac{(R_G + R_e)(I_F - I_G)}{I_G} \quad (1)$$

(c) Based on (a) and (b), draw a schematic of an ohmmeter.

2. In-lab activities

(1) Calibration of galvanometer

Connect a **high resistance resistor** (390 k Ω) (**why?**) with the galvanometer and the power supply to form a circuit, where the internal resistance of the galvanometer can be ignored. Give **at least five different output voltages** to make the pointer deflect. For each trial, use a multimeter to obtain the value of output voltage, calculate the standard current I_T and record the reading I_G from the galvanometer. Draw a graph of I_G versus I_T and use the relation you obtain to calibrate the current reading from galvanometer later.

(2) Internal resistance R_G of the galvanometer

Connect the galvanometer with the power supply. Start from 0.02 V and gradually increase the voltage provided by the power supply by 0.01 V until the full-scale deflection occurs. Use $V-I$ curve to determine the internal resistance R_G of the galvanometer. Compare the result with the value directly obtained by a multimeter. **Note that the voltage difference should be measured by a multimeter instead of direct reading from the power supply.**

(3) Ammeter design

(i) Design an ammeter of the maximum measured current being 50 mA. You should first calculate the resistance of the external resistor as asked in pre-lab Q1, and then find the resistor by the color code. (See Appendix A)

(ii) Connect the ammeter in series with a 150 Ω resistor and a DC power supply of 5 V output voltage.

(iii) Record the current obtained from the self-made ammeter. Substitute the ammeter with a multimeter to measure the current and compare the results.

(iv) Redesign the ammeter so that the maximum measured current is 5 mA and substitute the 150 Ω resistor with a 300 Ω resistor. Set the power supply of 1 V output voltage and redo step (iii).

(4) Voltmeter design

(i) Design a voltmeter with the equivalent maximum measured voltage being 10 V. You should first calculate the value of the external resistor as asked in pre-lab Q2, and then find the resistor by the color code. (See Appendix A)

(ii) Use the self-made voltmeter to measure the voltage difference across a 150 Ω resistor which is in series with a power supply of output voltage being 5 V.

- (iii) Substitute the voltmeter with a multimeter to do the measurement and compare the result with the reading from the self-made voltmeter.
 - (iv) Redesign the voltmeter with the equivalent maximum measured voltage being 2.5 V. Set the output voltage of the power supply to 1.5 V and redo step (iii).
- (5) Ohmmeter design
- (i) Design an ohmmeter with the output voltage of the power supply being 2 V. You should first calculate the value of the external resistor as asked to do in pre-lab Q3, and then find the resistor by the color code. (See Appendix A)
 - (ii) Use the self-made ohmmeter to measure the resistance of 390 Ω , 39 k Ω , and 390 k Ω resistor, respectively. Compare the result with the reading from the multimeter and the color codes.
 - (iii) Redesign the ohmmeter with the output voltage of the power supply being 0.4 V and 10 V, and redo the step (ii).
 - (iv) Discuss the accuracy of each trial conducted above.
3. Post-lab report
- (1) Recopy and organize your data from the in-lab tables in a neat and readable form.
 - (2) Analyze the data you obtained in the lab and answer the given questions

E. Questions

1. Use the color codes of the resistors used in the lab to estimate the uncertainties of the experiments. (Hint: propagation of uncertainty from Lab 1)
2. Discuss the applicable range of three different self-made ohmmeters. (Hint: Use $R-I$ graph and dR/dI to explain your reasoning)
3. During the experiment, the internal resistance of the power supply is not taken into consideration. Should it have been considered during the experiment? Explain your reasoning **in detail**. Also, find a way to measure the internal resistance of the power supply.
4. **(Optional)** The ammeter-voltmeter method is a general approach for measuring electrical resistances in the laboratory, most for pedagogical reasons. Two measuring configurations are usually proposed, depending on the relative values of the electrical resistance and the internal resistances of the ammeter and voltmeter. Read the following reference. Summarize the concepts and the difference of the two ways.

M. A. Salgueiro Da Silva and T. M. Seixas, *The Physics Teacher* **58**, 502 (2020).

F. References

- David T. Kagan , "A cheap simple ammeter for batteries-and-bulbs activities", *The Physics Teacher* 38, 204-205 (2000) <https://doi.org/10.1119/1.880504>
- M. A. Salgueiro da Silva and T. M. Seixas , "Effective Ammeter-Voltmeter Method", *The Physics Teacher* 58, 502-503 (2020) <https://doi.org/10.1119/10.0002072>

Appendix A: Color Codes

色碼	黑	棕	紅	橙	黃	綠	藍	紫	灰	白	金	銀	透明
Color	Black	Brown	Red	Orange	Yellow	Green	Blue	Violet	Gray	White	Gold	Silver	None
代表數字	0	1	2	3	4	5	6	7	8	9	-	-	-
倍率 (Multiplier)	10^0	10^1	10^2	10^3	10^4	10^5	10^6	10^7	10^8	10^9	10^{-1}	10^{-2}	-
誤差 (Tolerance)							+0.25% -0.25%	+0.1% -0.1%	+0.05% -0.05%	-	+5% -5%	+10% -10%	+20% -20%

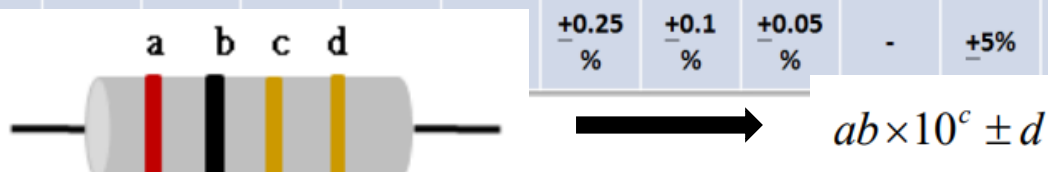

$$\therefore R = 20 \times 10^{-1} \pm 5\% = (2 \pm 0.1) \Omega$$